

# GATEWAY

## PROGRAMMABLE INDUSTRIAL PROTOCOL CONVERTER

- DIN Rail or Panel Mounted compact Protocol Converter
- DB9 Serial ports in any combination of RS232 / RS485(2wire / 4wire) / CMOS
- Connects PLC to PLC or PLC to a Modbus Network (as a Master or Slave)
- Allows data sharing between PLC, Invertors, Controllers and other network devices
- Common model for connecting different devices. Several PLC and Invertors supported
- Direct connection to the Programming terminal saves additional hardware
- Low power consumption of only 3.3 Watts
- CE, UL certification
- Flexisoft programing software.....Free



## SPECIFICATION

Power	+24V DC $\pm$ 10%, 140mA max
LED's	3 LED's for status indication
Communication Ports	2 Communication ports with RS232 / RS485 / CMOS (Isolation between communication ports and Power supply)
USB	1 micro-USB for programing
Temperature	Operating : 0° to +60°C Storage : -20° to +80°C
Humidity	10% to 90% (Non condensing)
Mounting	DIN rail or back panel mounting
Dimensions (DIN rail)	105mm(L) X 40mm(D) X 51mm(W)
Weight	125 gm approx.
Certifications	CE, UL.

## COMMUNICATION PORTS

The GWY-00 has two communication ports, PLC1 / COM1 and PLC2 / COM2. These ports are compatible to RS232 / RS485 and CMOS signal levels. The Pin-outs of these ports are as shown below:

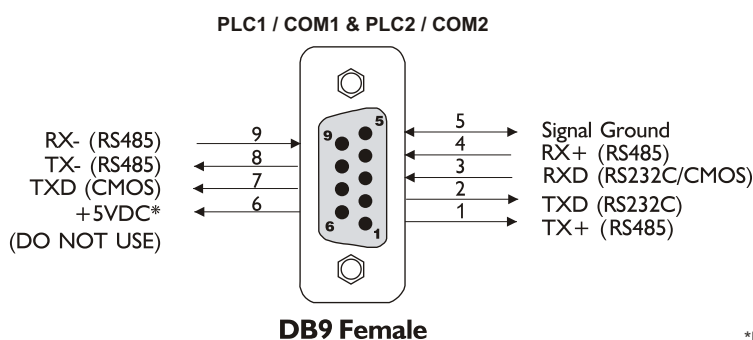

\*Do not use pin no. 6 of either of the GWY-00 communication ports.

## POSSIBLE APPLICATIONS

GWY-00 connects one field device to another over a serial link irrespective of their protocols. The user can define the blocks of registers to be fetched from one device and to be transferred to the other. Our users have used GWY-00 units in different applications across many industries. The typical configuration includes the following:

### 1. PLC TO PLC COMMUNICATION



### 2. PLC / INVERTER / CONTROLLER AS SLAVES ON MODBUS NETWORK

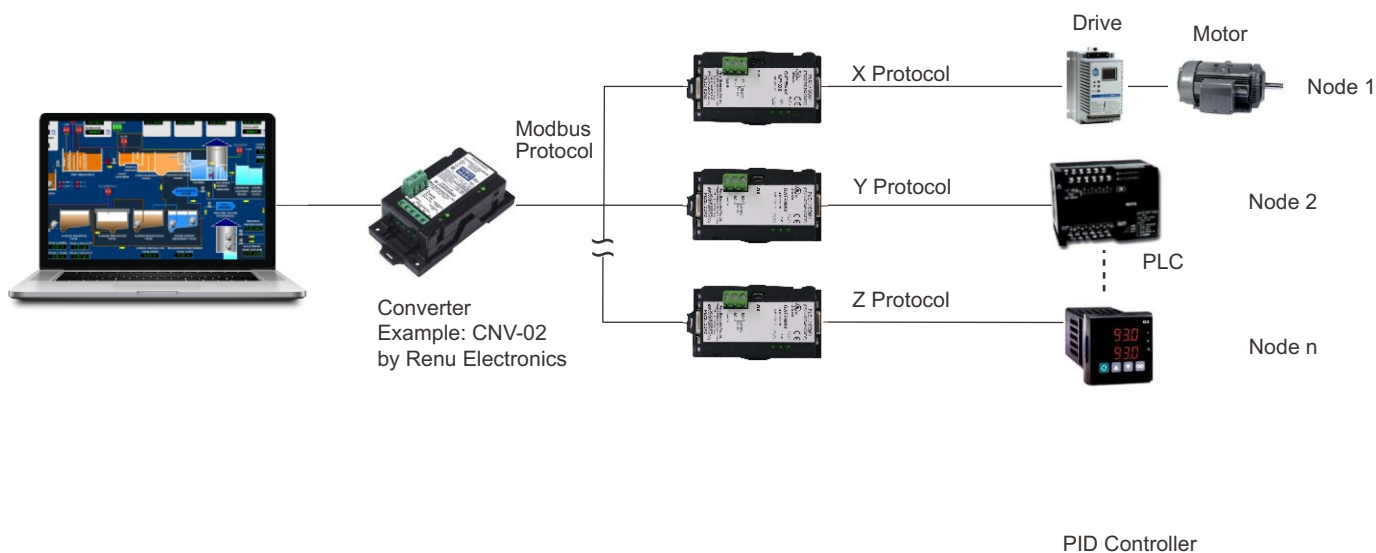

### 3. PLC AS MASTER IN MODBUS NETWORK

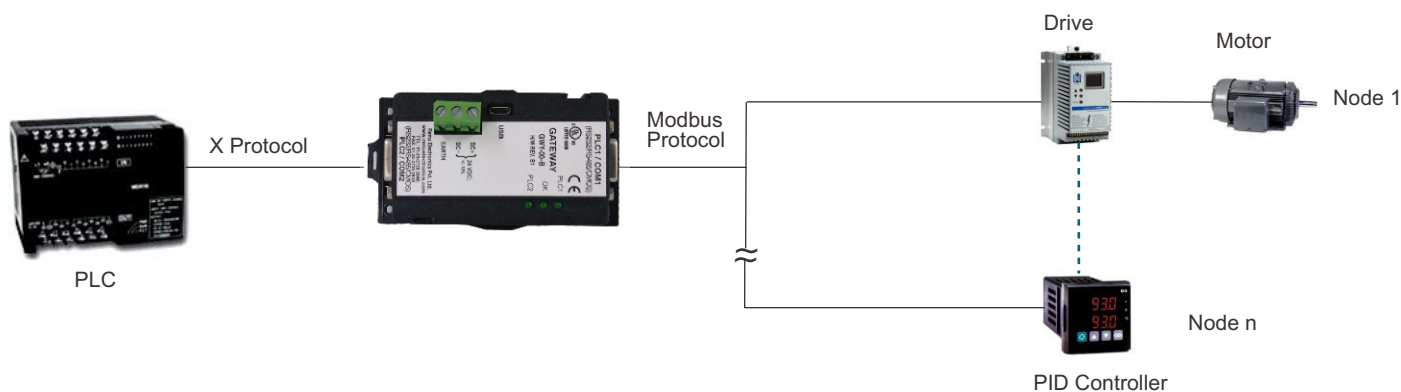

\* Images not to Scale.

## PROTOCOLS SUPPORTED

ABB PLCs  
Allen Bradley Df1  
Panasonic FP Series  
Baldor  
Danfoss Drive  
Delta PLCs  
Fatek PLCs  
GE SNP  
GE SNP-X  
Idec PLCs  
LG Master K Series PLC  
LG Master-K 300S  
Mitsubishi FX

Mitsubishi Q series PLCs (Serial)  
Modbus ASCII (Unit as Master)  
Modbus RTU (Unit as Master)  
Modbus RTU (Unit as Slave)  
Omron Host Link  
Omron Inverter Memobus  
Toshiba (Link Port) Series PLCs  
Toshiba Inverters PLC  
Toshiba T Series  
Twido PLCs  
Unitelway PLCs  
TriPLC  
Siemens Micromaster Driver (USS)  
FL Smidth Loadcell

## DIMENSIONS

Gateway units are shipped with a separate DIN rail plate which can be attached to the unit, if desired. The user can use the unit with or without the DIN rail plate. Following sketch shows dimensional details of Gateway with the DIN rail plate.

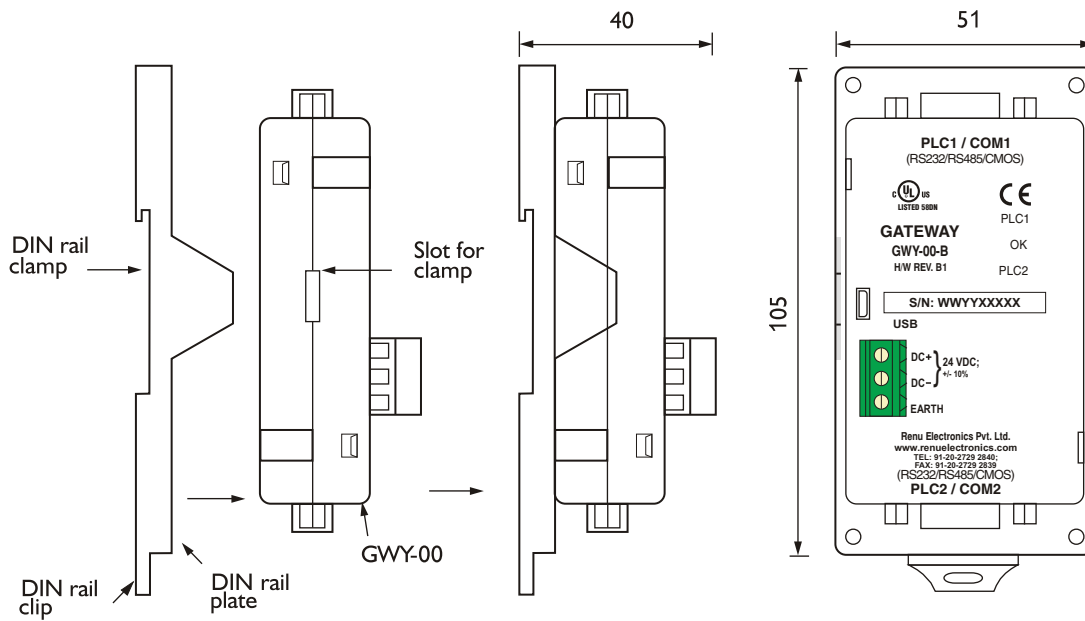

All dimensions are in mm. Please contact factory for more information.  
We welcome an opportunity to develop new, custom drivers and customized units.



### HEAD OFFICE

Survey No. 2/6, Baner Road, Pune - 411045, India.  
Tel : +91 20 2729 2840 - 46 Fax : +91 20 2729 2839  
Email : [info@renuelectronics.com](mailto:info@renuelectronics.com)  
Website : [www.renuelectronics.com](http://www.renuelectronics.com)  
An ISO 9001:2008 and ISO 14001:2004 certified company

(Preliminary Datasheet. Specifications subject to change without prior notice.)

(Specifications subject to change without prior notice. DS-GWY-00:Rev. 6L)